

A
B
C

SECTION RAX

REAR AXLE

RAX

CONTENTS

<p>PRECAUTION 2</p> <p>PRECAUTIONS 2</p> <p style="padding-left: 20px;">Precaution for Supplemental Restraint System (SRS) "AIR BAG" and "SEAT BELT PRE-TENSIONER"2</p> <p style="padding-left: 20px;">General Precautions2</p> <p>PREPARATION 3</p> <p>PREPARATION 3</p> <p style="padding-left: 20px;">Special Service Tool3</p> <p style="padding-left: 20px;">Commercial Service Tool3</p> <p>SYMPTOM DIAGNOSIS 4</p> <p>NOISE, VIBRATION, AND HARSHNESS (NVH) TROUBLESHOOTING 4</p> <p style="padding-left: 20px;">NVH Troubleshooting Chart4</p> <p>BASIC INSPECTION 5</p>	<p>AXLE SHAFT 5</p> <p style="padding-left: 20px;">On-Vehicle Inspection 5</p> <p>UNIT REMOVAL AND INSTALLATION 6</p> <p>AXLE OIL SEAL 6</p> <p style="padding-left: 20px;">Removal and Installation 6</p> <p>AXLE BEARING 7</p> <p style="padding-left: 20px;">Removal and Installation 7</p> <p>AXLE SHAFT 8</p> <p style="padding-left: 20px;">Exploded View 8</p> <p style="padding-left: 20px;">Removal and Installation 9</p> <p>SERVICE DATA AND SPECIFICATIONS (SDS)12</p> <p>SERVICE DATA AND SPECIFICATIONS (SDS)12</p> <p style="padding-left: 20px;">Axle Bearing12</p>	<p>E F G H I J K L M N O P</p>
---	--	--

PRECAUTIONS

< PRECAUTION >

PRECAUTION

PRECAUTIONS

Precaution for Supplemental Restraint System (SRS) "AIR BAG" and "SEAT BELT PRE-TENSIONER"

INFOID:000000007948695

The Supplemental Restraint System such as "AIR BAG" and "SEAT BELT PRE-TENSIONER", used along with a front seat belt, helps to reduce the risk or severity of injury to the driver and front passenger for certain types of collision. This system includes seat belt switch inputs and dual stage front air bag modules. The SRS system uses the seat belt switches to determine the front air bag deployment, and may only deploy one front air bag, depending on the severity of a collision and whether the front occupants are belted or unbelted. Information necessary to service the system safely is included in the SR and SB section of this Service Manual.

WARNING:

- To avoid rendering the SRS inoperative, which could increase the risk of personal injury or death in the event of a collision which would result in air bag inflation, all maintenance must be performed by an authorized NISSAN/INFINITI dealer.
- Improper maintenance, including incorrect removal and installation of the SRS, can lead to personal injury caused by unintentional activation of the system. For removal of Spiral Cable and Air Bag Module, see the SR section.
- Do not use electrical test equipment on any circuit related to the SRS unless instructed to in this Service Manual. SRS wiring harnesses can be identified by yellow and/or orange harnesses or harness connectors.

PRECAUTIONS WHEN USING POWER TOOLS (AIR OR ELECTRIC) AND HAMMERS

WARNING:

- When working near the Airbag Diagnosis Sensor Unit or other Airbag System sensors with the Ignition ON or engine running, DO NOT use air or electric power tools or strike near the sensor(s) with a hammer. Heavy vibration could activate the sensor(s) and deploy the air bag(s), possibly causing serious injury.
- When using air or electric power tools or hammers, always switch the Ignition OFF, disconnect the battery, and wait at least 3 minutes before performing any service.

General Precautions

INFOID:000000007948696

When installing rubber parts, final tightening must be carried out under unladen condition* with tires on ground.

* Fuel, radiator coolant and engine oil full. Spare tire, jack, hand tools and mats in designated positions.

PREPARATION

< PREPARATION >

PREPARATION

PREPARATION

Special Service Tool

INFOID:000000007948697

The actual shapes of Kent-Moore tools may differ from those of special service tools illustrated here.

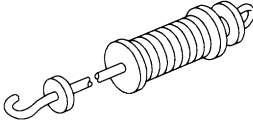
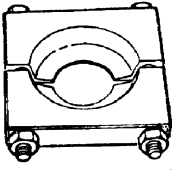
Tool number (Kent-Moore No.) Tool name	Description
KV40101000 (J-25604-01) Axle stand  NT159	Removing axle shaft
ST36230000 (J-25840-A) Slide hammer  NT126	Removing axle shaft
ST30031000 (—) Bearing splitter  ZZA0700D	Removing axle shaft bearing

Commercial Service Tool

INFOID:0000000008887681

Tool name	Description
Power tools  PIIB1407E	Loosening nuts, screws and bolts

NOISE, VIBRATION, AND HARSHNESS (NVH) TROUBLESHOOTING

< SYMPTOM DIAGNOSIS >

SYMPTOM DIAGNOSIS

NOISE, VIBRATION, AND HARSHNESS (NVH) TROUBLESHOOTING

NVH Troubleshooting Chart

INFOID:000000007948699

Use the chart below to help you find the cause of the symptom. If necessary, repair or replace these parts.

Symptom	Possible cause and SUSPECTED PARTS		Reference page						
	Improper installation, looseness	Parts interference	Wheel bearing damage	PROPELLER SHAFT	REAR FINAL DRIVE	SUSPENSION	TIRES	ROAD WHEEL	BRAKES
Noise	x	x		x	x	x	x	x	x
Shake	x	x		x		x	x	x	x
Vibration	x	x		x		x	x		
Shimmy	x	x				x	x	x	x
Shudder	x					x	x	x	x
Poor quality ride or handling	x	x	x			x	x	x	

x: Applicable

AXLE SHAFT

< BASIC INSPECTION >

BASIC INSPECTION

AXLE SHAFT

On-Vehicle Inspection

INFOID:000000007948700

REAR AXLE

- Check the axle parts for excessive play, wear, and damage. Replace as necessary.
- Shake each rear wheel to check for excessive play. Repair as necessary.
- Retighten all nuts and bolts to specification. Refer to [RAX-9](#), "[Removal and Installation](#)".

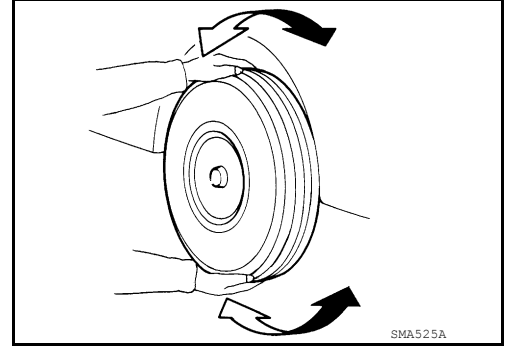

WHEEL BEARING INSPECTION

Check the axial end play, replace as necessary.

- Check that the axle shaft bearing operates smoothly. Replace as necessary.

A

B

C

RAX

E

F

G

H

I

J

K

L

M

N

O

P

AXLE OIL SEAL

< UNIT REMOVAL AND INSTALLATION >

UNIT REMOVAL AND INSTALLATION

AXLE OIL SEAL

Removal and Installation

INFOID:000000007948701

The axle oil seal and bearing ring retainer must be replaced every time the axle shaft is removed and installed. Refer to [RAX-9. "Removal and Installation"](#).

CAUTION:

- **Do not reuse the axle oil seal. The axle oil seal must be replaced every time the axle shaft assembly is removed from the axle shaft housing.**

AXLE BEARING

< UNIT REMOVAL AND INSTALLATION >

AXLE BEARING

Removal and Installation

INFOID:000000007948702

The axle oil seal and bearing ring retainer must be replaced every time the axle shaft is removed and installed. Refer to [RAX-9, "Removal and Installation"](#).

CAUTION:

- Do not reuse the axle oil seal. The axle oil seal must be replaced every time the axle shaft assembly is removed from the axle shaft housing.

A

B

C

RAX

E

F

G

H

I

J

K

L

M

N

O

P

AXLE SHAFT

< UNIT REMOVAL AND INSTALLATION >

AXLE SHAFT

Exploded View

INFOID:000000008887682

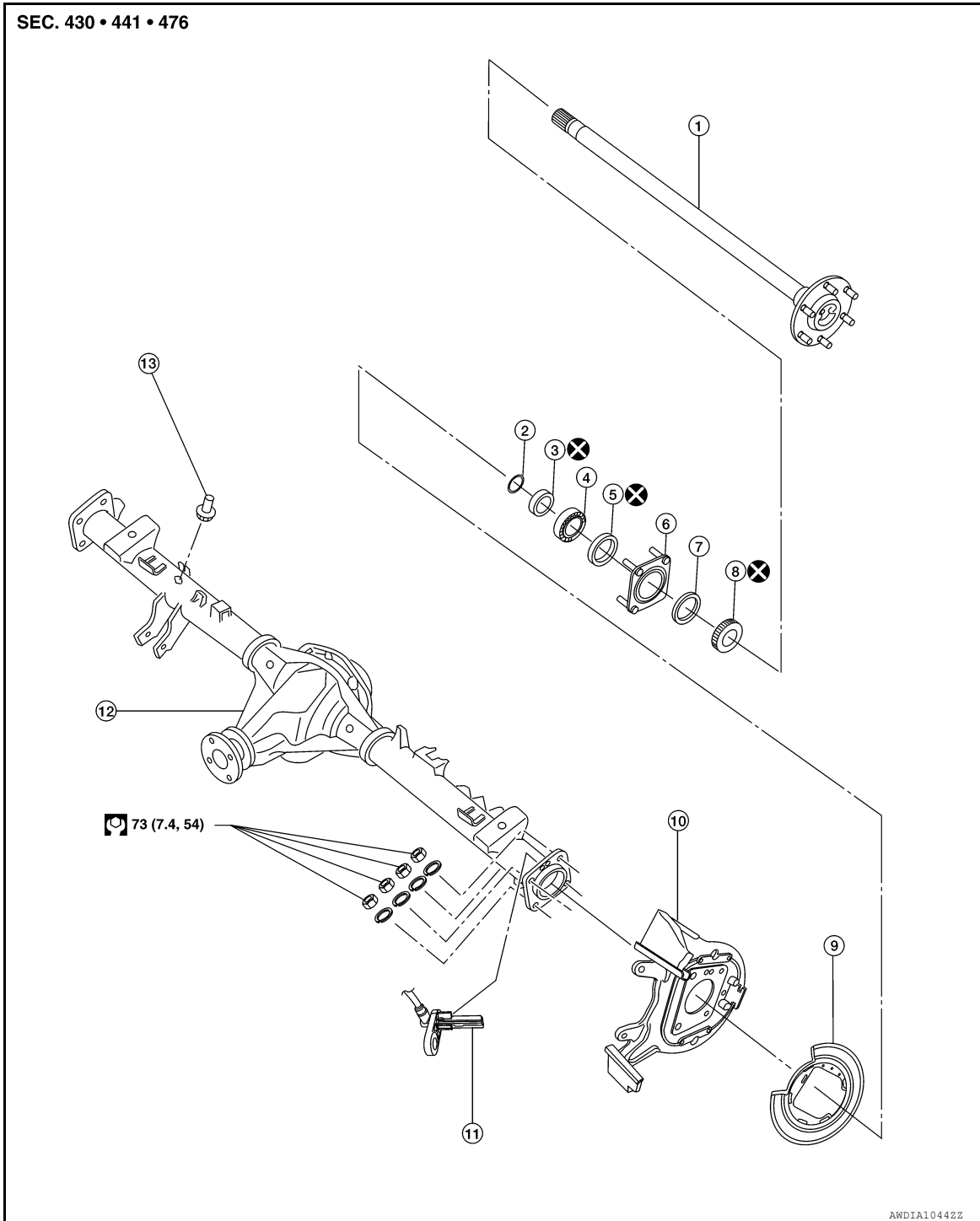

- | | | |
|-------------------------------|-----------------------|----------------------------|
| 1. Axle shaft | 2. Snap ring | 3. Bearing ring retainer |
| 4. Axle shaft bearing and cup | 5. Axle oil seal | 6. Axle shaft bearing cage |
| 7. Seal plate | 8. Wheel sensor rotor | 9. Back plate |
| 10. Torque member | 11. Rear ABS sensor | 12. Rear final drive |
| 13. Breather | | |

CAUTION:

AXLE SHAFT

< UNIT REMOVAL AND INSTALLATION >

- Before removing the axle shaft, remove the rear ABS sensor to reposition the rear ABS sensor out of the way. Failure to do so may result in damage to the rear ABS sensor and cause the ABS rear sensor to become inoperative.

Removal and Installation

INFOID:000000007948703

REMOVAL

1. Remove the rear ABS sensor. Refer to [BRC-113. "Removal and Installation"](#).
2. Remove the rear brake rotor. Refer to [BR-36. "Removal and Installation of Brake Caliper and Disc Rotor"](#).
3. Remove the parking brake assembly from the back plate. Refer to [PB-6. "Removal and Installation"](#).
4. Remove the four axle shaft bearing cage nuts and lock washers.

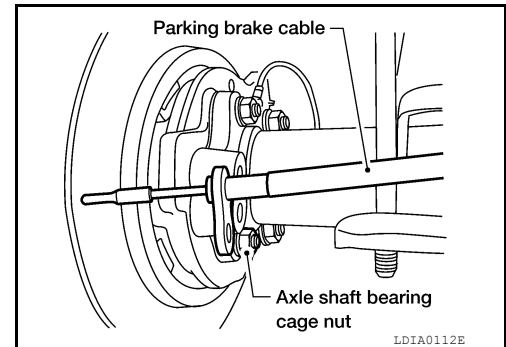

5. Remove the axle shaft assembly using Tools as shown.

CAUTION:

- The axle shaft bearing cup may stay in place in the axle shaft housing. Remove the cup carefully so as not to damage the inner surface of the axle shaft housing.
- Do not reuse the axle oil seal. The axle oil seal must be replaced every time the axle shaft assembly is removed from the axle shaft housing.

Tool number (A): KV40101000 (J-25604-01)
(B): ST36230000 (J-25840-A)

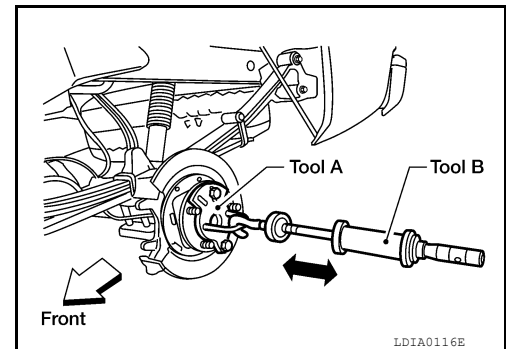

6. Remove the snap ring from the axle shaft using suitable snap ring pliers.
7. Secure the axle shaft in a suitable vise, then use a 1/4 in size drill bit to drill a hole approximately 3/4 into the thickness of the bearing ring retainer [3/4 thickness is approximately 6.3 mm (0.25 in) deep].

CAUTION:

- Mount the axle shaft using a soft jaw vise to avoid damaging the axle shaft.
- Do not drill all the way through the bearing ring retainer, the drill may damage the axle shaft surface.

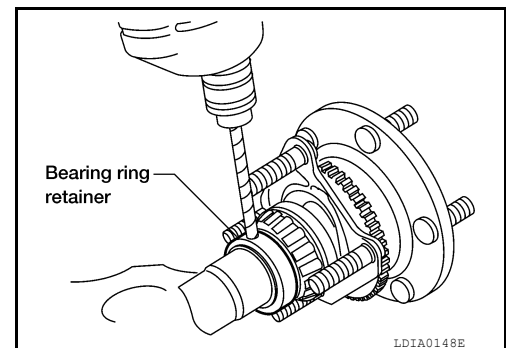

8. Strike the bearing ring retainer using a suitable chisel and hammer, with the chisel positioned across the drilled hole. Break the bearing ring retainer to remove it.

CAUTION:

- Do not heat or cut the axle shaft bearing or bearing ring retainer with a torch during removal, doing so will damage the axle shaft.

9. Remove the axle shaft bearing cage studs using a suitable hammer or press.

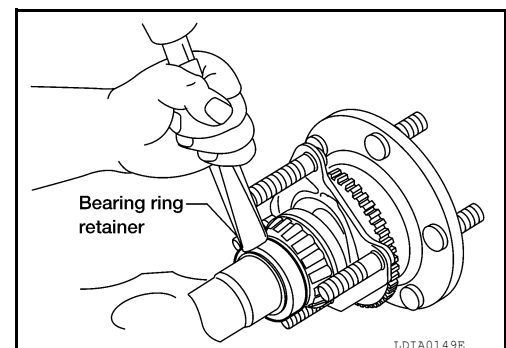

AXLE SHAFT

< UNIT REMOVAL AND INSTALLATION >

10. Pull the axle shaft bearing off of the axle shaft using Tool and a suitable press.

Tool number : ST30031000 (—)

CAUTION:

- Do not tighten the Tool against the axle shaft.
- Do not heat or cut the axle shaft bearing or bearing ring retainer with a torch during removal, doing so will damage the axle shaft.

11. Remove the axle oil seal and discard.

CAUTION:

- Do not reuse the axle oil seal. The axle oil seal must be replaced every time the axle shaft assembly is removed from the axle shaft housing.

12. Remove the wheel bearing cage.

NOTE:

- If reinstalling the old axle shaft, it may not be necessary to remove the seal plate and wheel sensor rotor. Inspect the seal plate and wheel sensor rotor and replace as necessary. Refer to [BRC-115. "Removal and Installation"](#).
- The wheel sensor rotor cannot be reused after it is removed. If replacing the axle shaft, install a new wheel sensor rotor on the new axle shaft. Refer to [BRC-115. "Removal and Installation"](#).

INSPECTION AFTER REMOVAL

Axle Shaft

- Clean and remove all nicks and burrs.
- Check for straightness and distortion. Replace if necessary.
- Inspect machined surfaces for evidence of overheating, damage and wear. Replace if necessary.
- Measure the bearing ring retainer axle journal diameter. Replace if necessary.

Bearing ring retainer axle journal diameter (minimum) : Refer to [RAX-12. "Axle Bearing"](#).

Axle Shaft Bearing and Cup

- Check that the axle shaft bearing and cup roll freely and are free from noise, cracks, pitting and wear. Replace if necessary.

Axle Shaft Bearing Cage

- Check for deformation and cracks. Replace if necessary.

Axle Shaft Housing

- Check the exterior and inner machined surfaces for deformation and cracks. Replace if necessary.

INSTALLATION

1. If installing a new axle shaft, install a new wheel sensor rotor onto the new axle shaft. Refer to [BRC-115. "Removal and Installation"](#).

CAUTION:

- Do not reuse the old wheel sensor rotor.

2. Install the seal plate.

3. Install the axle shaft bearing cage.

4. Install a new axle oil seal.

CAUTION:

- Do not reuse the axle oil seal. The axle oil seal must be replaced every time the axle shaft assembly is removed from the axle shaft housing.

AXLE SHAFT

< UNIT REMOVAL AND INSTALLATION >

5. Install the axle shaft bearing and cup on the axle shaft.
 - Prepare an installer tool from a steel tube measuring 762 mm (30 in) long with an outside diameter of 53.98 mm (2.125 in) and an inside diameter of 41.28 mm (1.625 in).
 - Press the axle shaft bearing and cup onto the axle shaft using a suitable press and the installer tool, until a 0.038 mm (0.0015 in) feeler gauge does not fit in between the axle shaft bearing cup and seat.

CAUTION:

- **Make sure the axle shaft bearing and cup, axle oil seal, and axle shaft bearing cage are installed facing in the correct direction.**

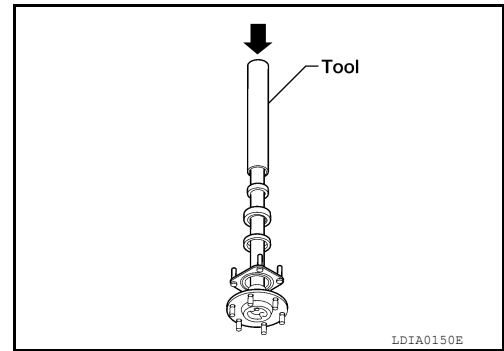

6. Install the bearing ring retainer onto the axle shaft.
 - Press the bearing ring retainer onto the axle shaft with a minimum force of 31,100 N (3172 kg, 6991 lb) until a 0.038 mm (0.0015 in) feeler gauge does not fit between the bearing inner race and the bearing ring retainer in at least one point.
7. Install the snap ring so it is fully seated into the groove on the axle shaft, using suitable snap ring pliers.
8. Install the axle shaft assembly into the axle shaft housing.
9. Install the axle shaft bearing cage lock washers and nuts. Tighten the axle shaft bearing cage nuts to specification.
10. Install the parking brake assembly onto the back plate. Refer to [PB-6, "Removal and Installation"](#).
11. Install the rear brake rotor. Refer to [BR-36, "Removal and Installation of Brake Caliper and Disc Rotor"](#).
12. Install the rear ABS sensor. Refer to [BRC-113, "Removal and Installation"](#).
13. Check gear oil level. Refer to [DLN-192, "Checking Differential Gear Oil"](#) (M226), [DLN-250, "Checking Differential Gear Oil"](#) (M226 w/ELD).

A

B

C

RAX

E

F

G

H

I

J

K

L

M

N

O

P

SERVICE DATA AND SPECIFICATIONS (SDS)

< SERVICE DATA AND SPECIFICATIONS (SDS)

SERVICE DATA AND SPECIFICATIONS (SDS)

SERVICE DATA AND SPECIFICATIONS (SDS)

Axle Bearing

INFOID:000000007948704

Bearing ring retainer axle journal diameter (minimum)	39.726 mm (1.5640 in) minimum
---	-------------------------------
